

# PROXXON

## *New Products 2010*

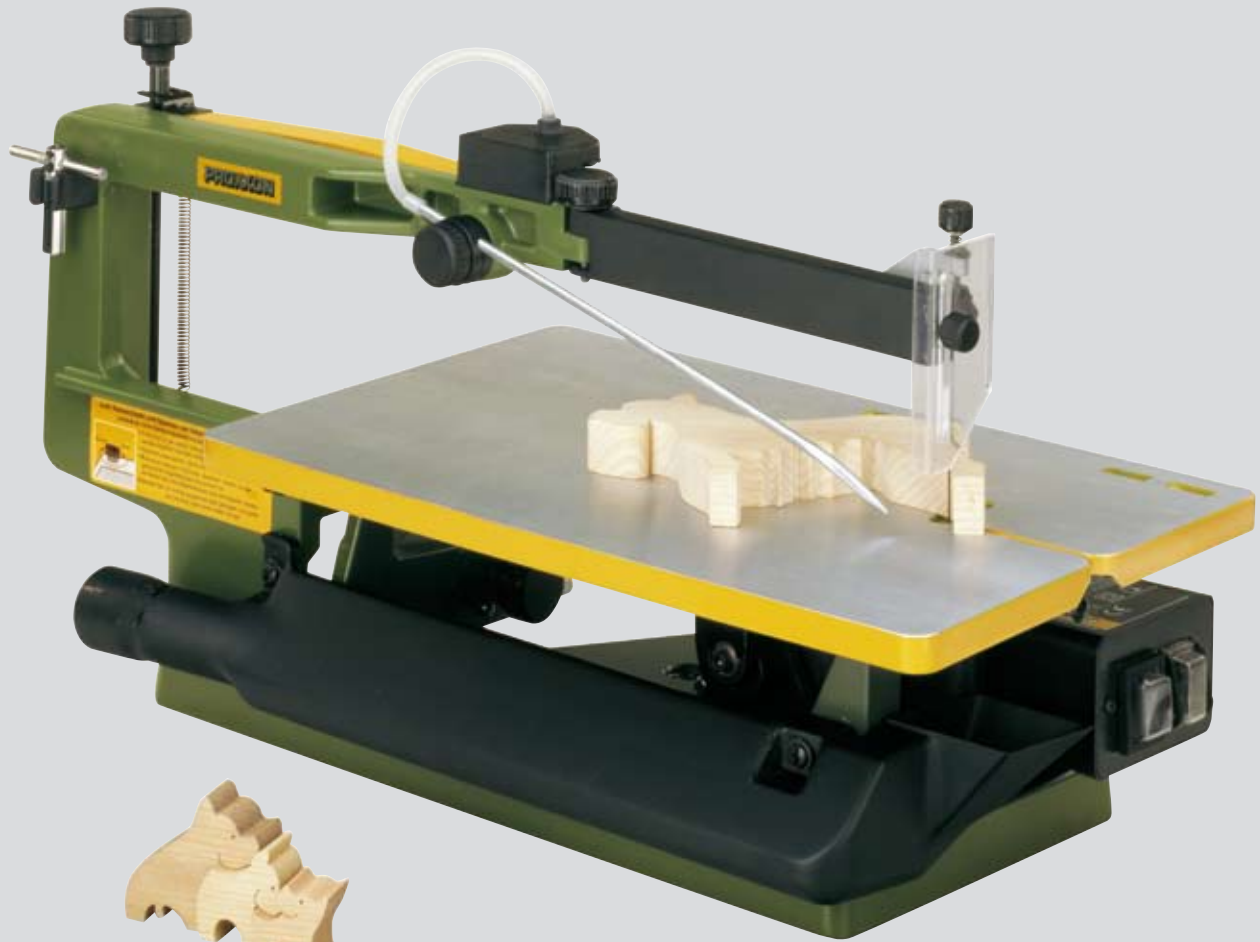

***Tools with character!***

## For demanding customers: The new 2-speed scroll



**Extremely quiet and vibration free. For clean cuts without refinishing.  
With a large throat of 460mm!**

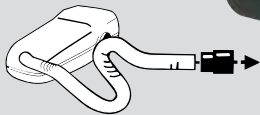
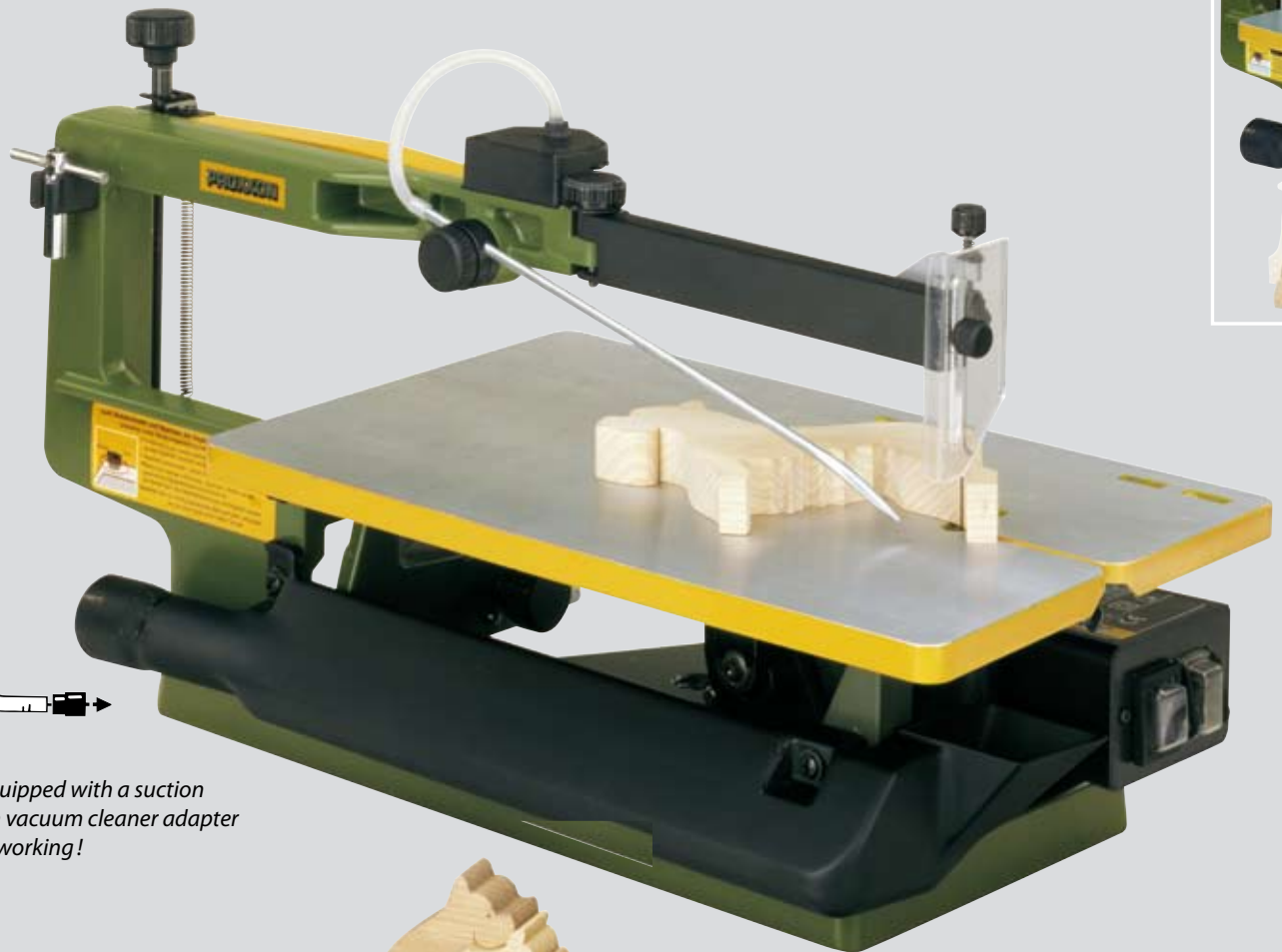
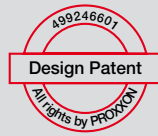

*The DS 460 is equipped with a suction connection with vacuum cleaner adapter to permit clean working!*



**Extremely light magnesium saw arms now reduce the weight of the mass to be moved by 40% as compared to die-cast aluminium. This makes the machine run even more quietly!**

Sturdy construction: Vibration-reducing base housing of cast steel, neatly CNC processed and powder-coated. For stability and working without vibrations. The extremely light and firm magnesium saw arms are precisely mounted on bearings, slender shape in the cutting area allows for an unobstructed view of the work piece. Chip blowing device with adjustable nozzle.

Die-cast aluminium saw table (size 400 x 250mm) can be unlocked and pushed back for easier saw blade replacement. Regular scroll saw blades are fastened by patented saw blade holders with high clamping force. This ensures true alignment in the saw arm.

The machine has also been prepared for saw blades with pin ends (are used without blade holders). Important: An adjusting knob enables sensitive clamping.

Cutting performance in wood 60mm, in non-ferrous metals (depending on type) 10 - 15mm. Easily cuts Plexiglas, glass fibre reinforced plastic, foam, porous concrete, rubber, leather or cork.

#### **Technical data:**

220 - 240V. Powerful, brushless 2-speed motor (205W). Throat 460mm. Stroke alternatively 900 or 1,400/min. Saw stroke 18mm. Table size 400 x 250mm. Maximum work piece passage 65mm (at 45° mitre 32mm). L 580mm, W 320mm, H 300mm. Weight approx. 20kg. Includes 5 each coarse and fine saw blades.

**NO 27 094**

## Roll saw DS 460

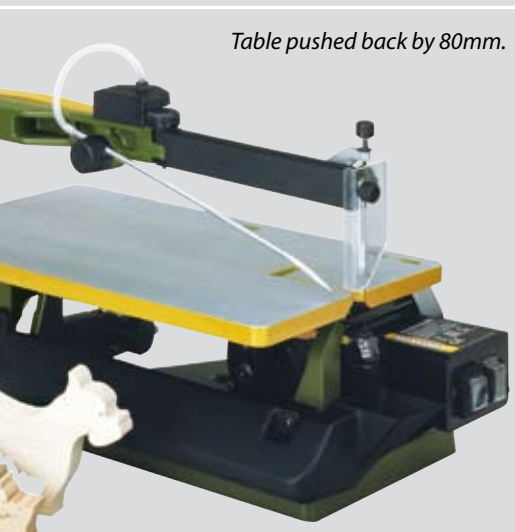

Innovative solution (patented): To enable easy saw blade replacement, the horizontally positioned table can be unlocked and pushed back by 80mm. For an unobstructed view of the bottom saw arm when fitting the saw blade holders or pin end blades.



Patented saw blade holders with high clamping force ensure true alignment of the blades. Recesses in the table surface serve as guide line in assembly to define position and distance of the blade holders.



Table angle adjustment possible from -5° to 50°. With large dimensioned serrations at 0°, 10°, 20°, 30° and 45°. Additional fine adjustment for precise mitre and angle cuts.

## MICRO Heat gun MH 550

**Small, robust and powerful. Complete with 3 additional nozzles.**

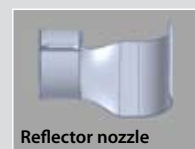

**For shrinking sleeves (most currently available devices are simply too large) and 1000's of other kinds of work:**

For shaping and welding plastics, soldering and de-soldering electrical components, for removing layers of paint and varnish without aggressive chemicals (pickling agents), for drying and accelerating curing processes (adhesives, paints), for applying and removing films (stickers), for browning wood.

Housing of glass fibre reinforced POLYAMIDE with soft components in the grip area and footprints for stationary use. A powerful heating element ensures a consistent temperature in 2 stages with an air flow of 180 l/min. Installed thermostat as security against overheating. Device nozzle of stainless steel. With 3 push-on nozzles.

### Technical data:

220 – 240V. 500W. Air temperature in Stage 1: 350°C. Stage 2: 550°C. Air volume approx. 180 l/min. Weight approx. 500g.

**NO 27 130**

### Diamond-coated cutting disc with cooling holes (Ø 38mm)

For greater cutting depths and an even higher removal rate. For cutting and grinding hard and brittle materials such as porcelain, ceramics, glass, marble, concrete, stone, non-ferrous metals, plus plastic, glass fibre, reinforced plastic and epoxy circuit boards. Ideal for deburring. Cooling holes reduce heat generation and prevent burning. Arbor shaft 2.35mm.

**NO 28 846**

38 x 0.6mm



### Protective cover for hand-operated MICROMOT machines with standard 20mm collar

For work with saw blades, cutting discs, milling bits, grinding tools, steel brushes and polishing tools. Maximum useable tool diameter 22mm. Easy to mount.

**NO 28 944**



## MICRO Cutter MIC

**Materials up to 4mm thickness are cut effortlessly and cleanly with a cutting width of only 0.5mm.**

A powerful DC special motor in this compact device ensures an astonishingly high cutting performance when cutting wood, plastics, glass fibre reinforced plastic, paper, cardboard, foil and similar materials.

Slim and light: A diameter of just 36mm makes the ergonomically shaped casing easy to handle and unrivalled for fatigue-proof work and accurate guiding.

**Important:**

The MIC makes it possible to „dip in“ to the work piece surface (e.g. for cut-outs). The saw blade guard folds up automatically during cutting.

**Technical data:**

220 – 240V. 30W. 15,000/min. Maximum cutting depth 4mm. Cutting width 0.5mm. Weight approx. 300g. Class 2 insulation.

**NO 28 650**

A screwdriver for saw blade replacement is included in the package.



**Replacement cutting disc for MICRO-Cutter MIC**



Made of spring steel (hardness 55 HRC). With cleanly ground crossed teeth. 23 x 0.1 mm with 2.6mm boring.

**NO 28 652**



## Edge milling attachment KAVO

**Fits all machines with MICROMOT system 20mm collar.**

For chamfering and bevelling inside and outside edges of wood, plastic and metal work pieces. Also suited for glass and ceramics when using suitable accessories.

A 20mm flange on the KAVO enables stationary use in conjunction with the universal holders UHZ or UHV.

Cylindrical milling bits up to a 10mm diameter maximum can be used in the central position (45°). The angle can be adjusted to both sides by 15°. For bevels from 30° to 60°.

Differently shaped milling bits can also manufacture round edges, hollow edges, chamfers for seals (example: ball-milling bit for O-ring seals).

**NO 28 612**



Precise parallel guide. Adjusts for different chamfering widths and depths.



The parallel guide can be removed when processing round or curved work pieces. The remaining cylinder is then used as limiter.

# MICRO Miller FF 500 - ready for CNC

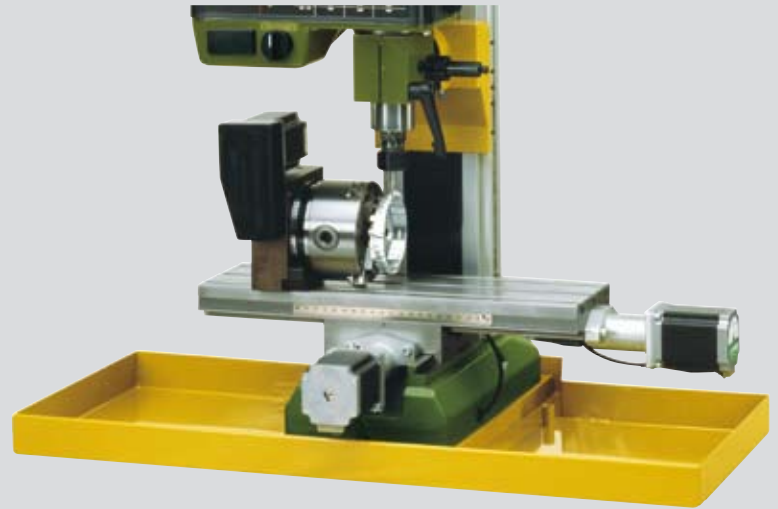

## **Splash guard and chip collecting tray for PROXXON milling machines**

Suitable for FF 230, FF 400, FF 500, FF 500/CNC (and ready for CNC) and the set-up BFB 2000 with KT 150. Made from 1.5mm thick sheet metal. Corrosion-resistant due to high-quality powder coating. Sturdy stand with drill holes for fastening to a work surface (the use of steel sleeves keeps the tray tightly sealed). L 700 x W 420 x H 40mm. The illustrated MICRO Miller is not included in the specification.

**NO 24 322**

## **With recirculating ball spindles and powerful step motors at all 3 axes. Without CNC control unit and without software.**

For users who already have a control unit. Three standard plugs (SUB-D 9POLE) are available to connect the control unit. The mechanical construction of the MICRO Miller is identical to the MICRO Miller FF 500/CNC.

**NO 24 344**



### ***Dividing attachment UT 400/CNC***

***The 4th axis to the PROXXON MICRO Miller FF 500/CNC.***

***For perfect 3D processing.***

For individual parts and small series production. For manufacturing divisions, gear wheels, helical gearings, screw spindles and (including irregular) profiles. All angle positions can be approached by computer control. Easy horizontal and vertical construction.

Driven by powerful step motor (2.0A) through toothed belts, and virtually free from play, adjustable worm gear. The high transfer ratio (40:1) provides enormous torque.

Main spindle with 14mm drill hole and flange to suit face plates and all lathe chucks from the PD 400 lathe system.

Smallest increment 0.003°. Recognition of reference position through light barrier.

**Chuck and work pieces are not included in the package.**

**NO 24 423**

**Note:**

*The 4th axis is implemented in the MICRO Miller FF 500/CNC software as standard.*

*The control unit (hardware side) is only equipped with the necessary driver stage as of serial no. 223-Fräsen.*

### ***14-piece parallel supports set***

For adjusting work on drill machines, lathes and milling machines. Of high-alloy steel, hardened (58 - 62 HRC) and ground in pairs. Parallel accuracy 0.002mm.

2 each of 8 x 10, 15, 20, 25, 30, 35, 40 and 100mm. Packed in a wooden box.

**NO 24 266**



[www.proxxon.com](http://www.proxxon.com)

**PROXXON –  
The fine tool company!**